

PLAN VIEW

2'-0" LONG GALVANIZED CHANNEL
(1) EACH WALL

4.5" DUCT TERMINATOR
(2) EA. WALL, (2) WALLS

3.51" DUCT TERMINATOR
(2) EA. WALL, (2) WALLS

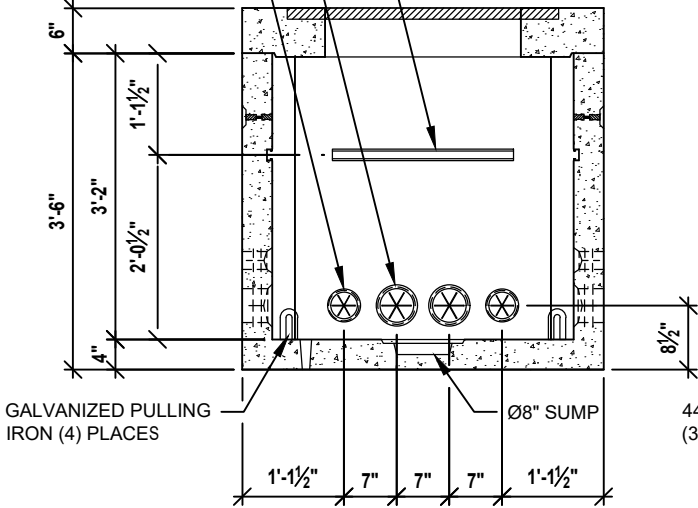

SECTION A-A

4.5" DUCT TERMINATOR
(1) EA. WALL, (2) WALLS

3.51" DUCT TERMINATOR
(4) EA. WALL, (2) WALLS

(4) Ø 3/8" GROUNDING INSERTS
(2) INSIDE WALLS, (2) OUTSIDE

2.38" DUCT TERMINATOR
(1) EA. WALL, (2) WALLS

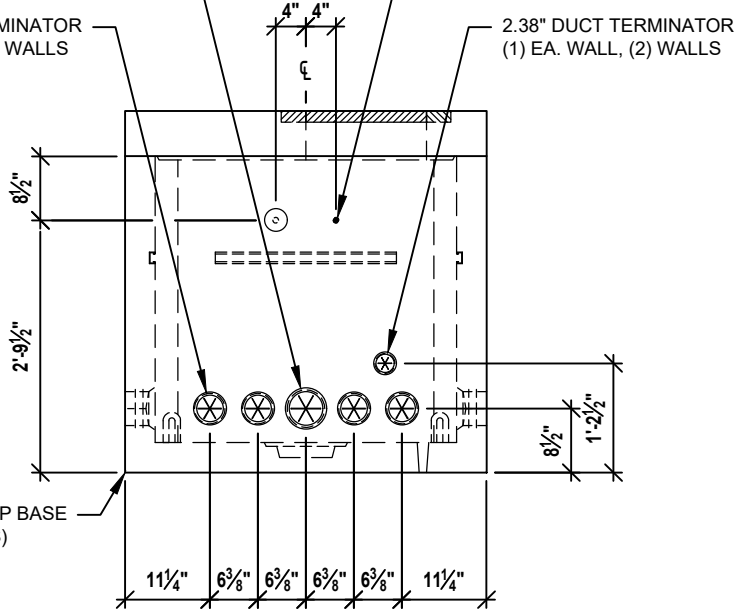

VIEW - B

NOTES:
1. WEIGHTS LISTED ARE APPROXIMATE.

PCORP ZG501 06-13-13